

TECHNICAL MANUAL

**OPERATOR'S, UNIT AND
DIRECT SUPPORT MAINTENANCE MANUAL
(INCLUDING REPAIR PARTS AND SPECIAL TOOLS LIST)
FOR**

SARTORIUS ANALYTIC BALANCE

MODEL A 200 S

This technical manual is an authentication of the manufacturer's commercial literature and does not conform with the format and the content requirements normally associated with Army technical manuals. This technical manual does, however, contain all essential information required to operate and maintain the equipment.

Approved for public release; distribution is unlimited.

**HEADQUARTERS, DEPARTMENT OF THE ARMY
10 OCTOBER 1990**

This technical manual is an authentication of the manufacturer's commercial literature and does not conform with the format and the content requirements normally associated with Army technical manuals. This technical manual does, however, contain all essential information required to operate and maintain the equipment.

Approved for public release; distribution is unlimited.

SUPPLEMENTARY INTRODUCTORY MATERIAL

1-1. Maintenance Forms and Records.

Department of the Army forms and procedures used for equipment maintenance will be those described by DA Pam 738-750, The Army Maintenance Management System.

1-2. Reporting Errors and Recommending Improvements.

You can help improve this manual. If you find any mistakes or if you know of a way to improve the procedures, please let us know. Mail your letters, DA Form 2028 (Recommended Changes to Publications and Blank Forms), or DA Form 2028-2 located in the back of this manual, directly to: Commander, U.S. Army Troop Support Command, ATTN: AMSTR-MCTS, 4300 Goodfellow Blvd., St. Louis, MO 63120-1798. A reply will be furnished to you.

1-3. Destruction of Army Material to Prevent Enemy Use.

Refer to TM 750-244-3 for instructions covering the destruction of Army Material to prevent enemy use.

1-4. Administrative Storage of Equipment.

a. Placement of equipment in administrative storage should be for short periods of time when a shortage of maintenance effort exists. Items should be in mission readiness within 24 hours or within the time factors as determined by the directing authority. During the storage period appropriate maintenance records will be kept.

b. Before placing equipment in administrative storage, current preventive maintenance checks and services should be completed. Shortcomings and deficiencies should be corrected, and all modification work orders (MWO's) should be applied.

c. Storage site selection. Inside storage is preferred for items selected for administrative storage. If inside storage is not available, trucks, vans, conex containers and other containers may be used.

Sartorius Analytic. A 200 S.

**Electronic Analytic Balance
Installation and Operating
Instructions**

**Electronic analytical balance
Installation and operating instructions**

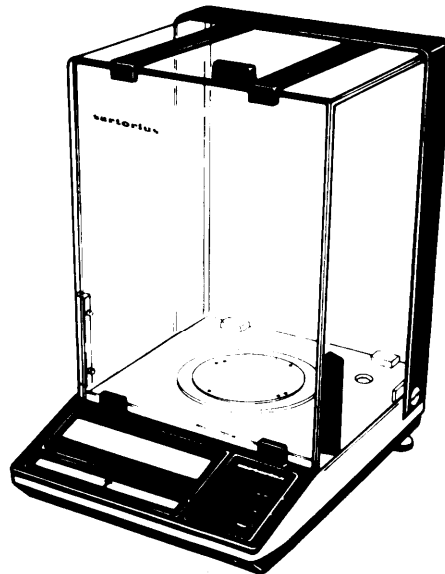

sartorius

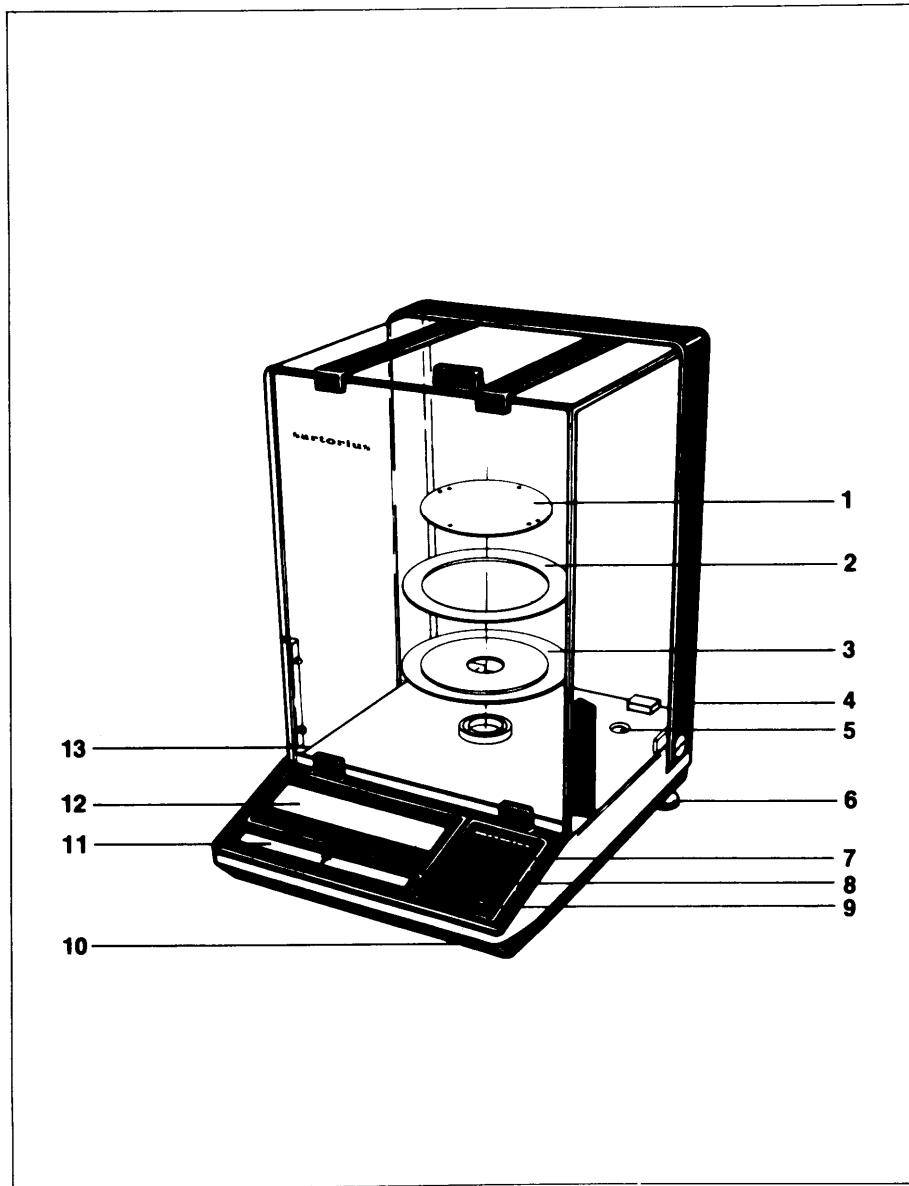

1 Pan

2 Protective ring

3 Shield plate

4 Connection socket for power cable

5 Level indicator

6 Leveling screw

7 ON/OFF button

8 CAL button

9 PRINT button (functions only in conjunction with the optional data output)

10 Menu access switch

11 Tare bar

12 Weight display

13 Manufacturer's label

Sortorius analytic. A 200 S.

With this Sartonus toploader you have acquired a sophisticated, top-of-the-line electronic balance, which will help lighten your daily workload.

Please read these installation and operating instructions carefully before operating your new toploader.

Technical data.

Model		A 200 S
Weighing range	g	202
Readability	g	0.0001
Tare range (by subtraction)	g	202
Standard deviation	g	$\leq \pm 0.0001$
Max. linearity deviation	g	$\leq \pm 0.0002$
Stabilization time (typical)	s	3
Display update rate	s	0.1 -0.8 (selectable)
Adaption to environment and application requirements		by selection of one of four digital filter levels
Stability range	d	selectable from 0.25...64
Ambient temperature range.....	K	283...313
Sensitivity drift within 283...303K	/K	$\leq \pm 2 \cdot 10^{-6}$
Deviation from result when tilted 1:1000	g	$\leq \pm 0.0001$
Calibration weight		built-in, standard
Pan dimension	mm	$\varnothing 90$
Clearance above pan	mm	257
Weighing chamber (WxDxH)	mm	200 x 184 x 265
Balance housing (WxDxH)	mm	230 x 291 x 343
Net weight	kg	7.5
Line voltages, frequencies 50-60 Hz.....		100/120V or 220/240 V, depending on the power supply (adapter) being used
Consumption	VA	9
Interface		RS 232 C/V24-V28, RS 423/V10; 7-bit; parity: even, mark, odd, space; transmission rates 150...9600 Baud

Installation instructions.

Choose a suitable installation site largely free of

- heat radiation
- corrosive substances
- vibrations
- drafts.

Despite unfavorable operating conditions, your MP8 balance will deliver accurate weight results. Simply adapt it to your requirements by programming the appropriate codes via the balance operating program. For this purpose, please refer to the final pages of the English section.

After connection to line power, allow for >30 minutes warmup.

Important!

Pull out the power supply unit (AC/LDC adapter) prior to connecting or disconnecting peripherals.

Accessories (optional)

Carrying case	YDB01 A
Theft prevention lock	6087
Data output	YDO 0 1 A
Integratable keyboard "Data Input"	
with F for formulation	YDI 0 1 A- * *F
Printer "Data Print"	YDP 0 1

Complete Consignment.

Please complete the guarantee card, indicating the installation date, and return the card to your Sartonus dealer.

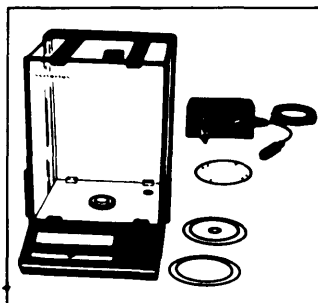

Complete consignment

A complete consignment consists of the illustrated components plus a dust cover.

Startup.

Install components **(3 – 1)** in the weighing chamber one at a time in the indicated sequence.

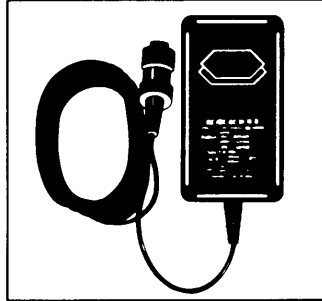

Your balance is supplied via the power supply unit. Please check if the voltage printed on this adapter is identical to that of your local line voltage.

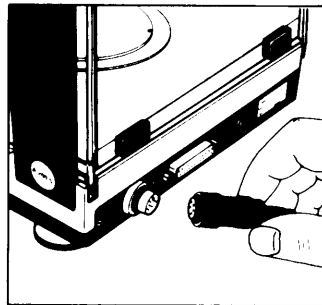

Make the power connection. Secure the connection with the threaded ring. Now connect the power supply unit to a line outlet.

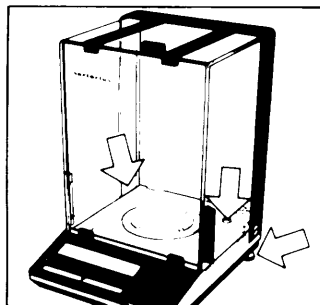

At the point of use, level the balance using the leveling screws **(6)** such that the air bubble is centered in the circle of the level indicator **(5)**.

Operation.

The weight display provides the following special messages for your information:

BUSY

The processor is still busy processing other information and will not accept other functions at this time.

STANDBY

The balance was switched off with the ON/OFF function and is now in the STANDBY mode.

POWER OFF

The balance was separated from line power (fresh power connection, power failure).

CAL

The calibration function has been called.

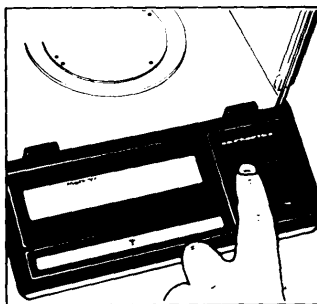

Use the ON/OFF button (7) for switching on or off. You can also switch on with the tare bar (11).

After connection to line power, only the weight display will go off whenever you switch the balance off. The electronic circuits remain power-supplied (STANDBY). This feature provides for instant operability the moment you switch on, without having to wait for warmup.

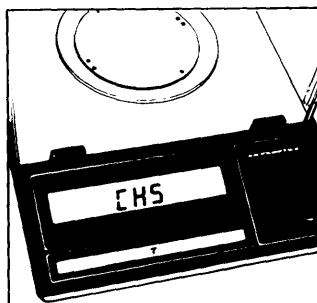

After power-on, there is an automatic test of all electronic functions. Successful completion of the test is signaled by 0.0000 g in the weight display.

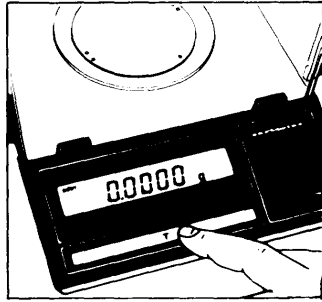

You must zero the display prior to weighing, if you are using a container or if the weight display does not read 0.0000 g (or the equivalent with the weight unit of your choice).

Calibration.

Internal Calibration:

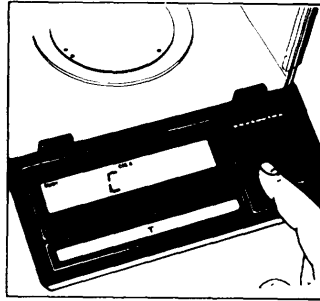

Clear the pan and zero the display. Once the display reads 0.0000 g, push the CAL button (8). The display now reads "C". If you get "CE", zero the display and push the CAL button again.

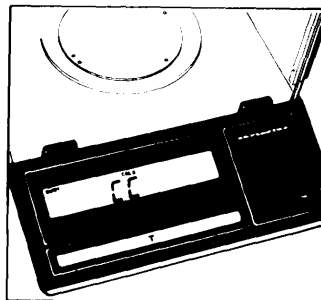

After a few seconds, the display will read "CC", followed by 0.0000 g. A beeper confirms successful completion of calibration.

External calibration:

This requires an accurate calibration weight.

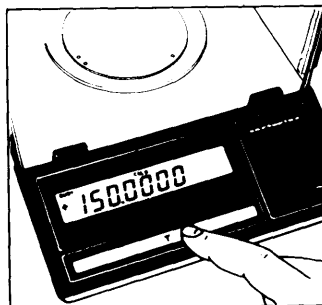

Clear the pan and depress the tare button for at least three seconds until the calibration weight appears in the display.

Place the calibration weight on the pan.

Now the weight unit symbol appears and a beeper sounds to signal completion of calibration.

You can lock both the external and the internal calibration function – see “Balance operating program.” Both functions are active whenever the balance operating program has been unlocked with the access switch.

In addition to grams, this balance gives you a variety of other international weight unit options to work with.

Select the weight unit you need from the table in the balance operating program, and set the appropriate code as described in section “Balance operating program.”

Balance operating program.

The balance operating program permits adaption of your balance to ambient conditions at the point of use and different weighing requirements, plus selection of various weight units. At the factory, we have set the codes for a standard program, which is protected by a locking function to prevent accidental changes.

The “**code**” is the information carrier of the operating program. It consists of three digits: one each for the page, the line and the word.

Access to the balance operating program:

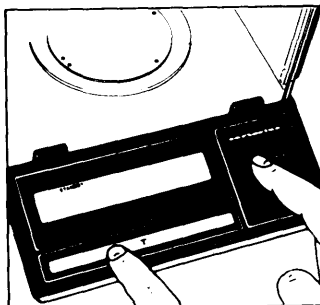

Activate the ON/OFF button while at the same time depressing the tare bar.

After completion of the automatic power-on test, the status of the balance operating program appears in the weight display: "L" stands for the list mode. In this mode, you can only verify the code setting, but you cannot program new codes. If you want to change a program code, you must first unlock the program access.

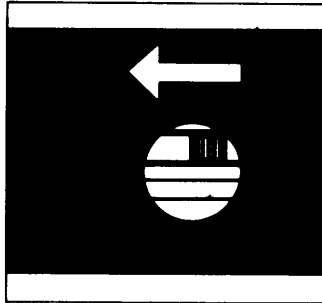

To do so, slide the unlocking switch (10) at the forward right of your balance in the arrow direction.

The display will signal "C" representing the change mode, and you can now proceed to make the necessary code changes.

After the balance operating program has been called, the display will show a continuous numerical sequence from 0 to 5 representing the page selection, in addition to the status signal "L" or "C". When your selected number for the "page" appears, push the tare bar. The "page" code number is now fixed in the display, and the cycle for the "line" starts. Again confirm your selected number with the tare bar, and your selection will be fixed. Next the "word" cycle appears,

When the 0-symbol appears, this marks the actual setting.

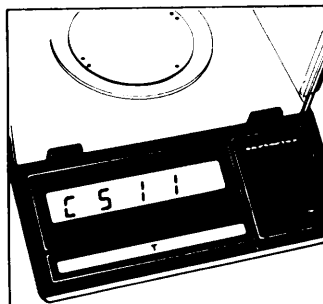

To make changes ("C" mode), press the tare bar when the appropriate code appears.

Brief display of "BUSY" and the 0-symbol confirms your selection, followed by return to the "zero" representing the "line".

To return to the weighing program:

push the tare bar each time a 0 appears in the numerical cycle (word, line, page). If you have made code changes, your code entry is stored as soon as the display returns to the weighing mode. Lock the balance program with the menu access switch (display "L") and replace the protective cap.

Auto-zero

This balance has an automatic zero tracking function. Any change off zero <2 digits per second will be set to zero automatically.



page line word

Balance operating program (active parameters)

Code	Environment	factory setting	Code	Internal calibration	factory setting
[1]	very stable		[1]	accessible	■
[2]	stable	■	[2]	locked	
[3]	unstable		Special information		
[4]	very unstable		Code	Program lock	
Code			[1]	OFF	
[1]	0.25 digit		[2]	ON	■
[2]	0.5 digit		Code		
[3]	1 digit		[1]	Beeper	
[4]	2 digits		[2]	ON	■
[5]	4 digits	■	[2]	OFF	
[6]	8 digits		Code		
[7]	16 digits		[1]	Weight units	
[8]	32 digits		[1]	grams	g
[9]	64 digits		[2]	kilograms	kg
Code			[3]	carats	ct
[1]	last decimal ON		[4]	pounds	lb
[2]	last decimal OFF	■	[5]	ounces	oz
[3]	last decimal at stability		[6]	troy ounces	ozt
[4]	all decimals at stability		[7]	parts/pound	o
Code			[8]	taels Hongkong	tl
[1]	Tare mode		[2]	taels Singapore	tl
[2]	without stability	■	[3]	taels Taiwan	tl
[2]	at stability		[4]	grains	gr
Code			[5]	pennyweights	dwt
[1]	Auto-zero		[6]	momnes	o
[2]	ON	■	[7]	milligrams	o
[2]	OFF		[8]	karats	o
Code			[20]	call program line	
[51]	External calibration		[10]	call program page	
[52]	accessible	■	end of programming		
[52]	locked		[]		

Additional parameters for the data output format and for calculator programs are available on request. – Please refer to “Accessories.”

ADDENDUM A

This addendum to the Sartorius Publication Number WA6002 m7/86 covers the Sartorius Analytic Balance Model A 200 S and contains the following information:

Paragraph	Title
1	Preventive Maintenance Checks and Services
2	Troubleshooting
3	Maintenance Remove/Replace Procedures
4	List of Recommended Spare Parts

1. Preventive Maintenance Checks and Services for Sartorius Analytic Balance (Model A 200 S).

Routine maintenance ensures trouble-free operation. Checks and services listed below should be conducted daily and prior to each use.

<u>Check/Service</u>	<u>Note</u>
Check that glass plates are not cracked, chipped, or dirty.	Remove glass to clean.
Check that interior of weighing compartment is clean.	Remove weighing pan and wipe interior clean using a lint-free, dry cloth. Remove dust particles with camels hair brush. Clean and replace weighing pan.

2. Troubleshooting. Troubleshooting this equipment consists of observing results of normal operations and results of running both the external and internal calibration checks. It also includes a thorough visual inspection of the measuring cell and all electrical connections.

a. If you detect the following problems:

- poor reproducibility
- display hysteresis
- nonreproducible corner load
- permanent "L" in the display
- skipping display

you are very likely dealing with a mechanical fault.

b. If you find:

- error message in the display
- display dark or display segments missing

you are very likely dealing with an electronic error.

3. Maintenance – Remove/Replace Procedures.

3.1 Remove/Replace the Display Panel.

- a. Remove weighing pan, ring, shield plate, and base plate from the balance. Unscrew three screws (1) from the hood and carefully lift hood to the right and place next to balance.

NOTE

The display panel includes the tare pcb, when the balance has basic equipment.

- b. Remove the keyboard overlay (2) in the display panel (3). Remove screw (4) in the display panel.

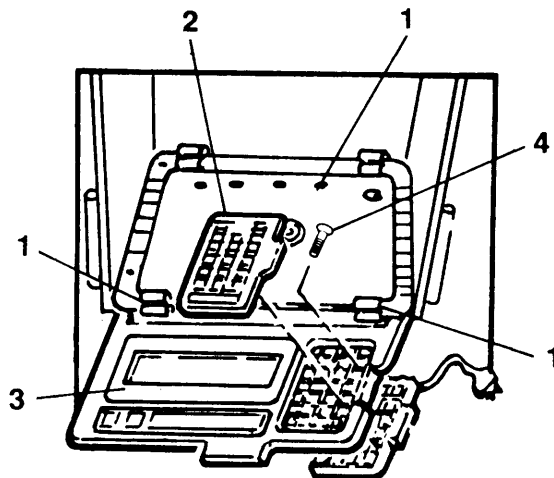

CAUTION

Do not touch the screen with your fingers. It is coated with a protective film.

- c. Unplug connection (5).
 - d. Remove the eight screws (6). Carefully take off display panel.
 - e. Replace display panel in reverse order.
- e. Replace display panel in reverse sequence.

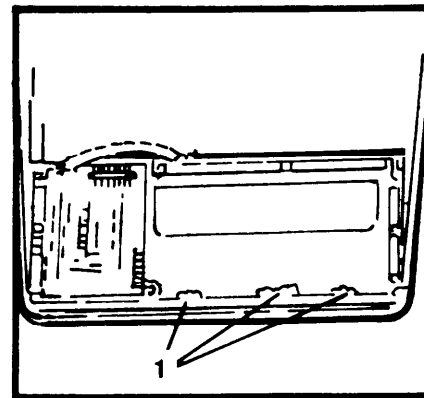
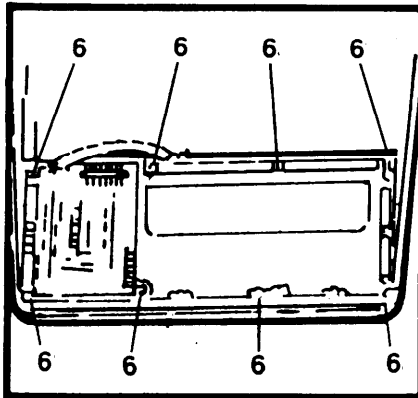
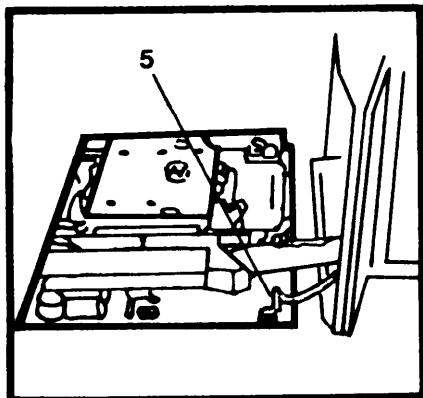

3.2 Remove/Replace the Tare Key Overlay.

- a. Open the balance (see paragraph 3.1 a).

CAUTION

Do not touch the screen in the display with your fingers. It is coated with a protective film.

- b. Remove three clamps (1). Remove overlay from the display panel.
- c. Take off the protective cover from the new overlay with touchpad.
- d. Insert tare key overlay with the three ground connections in the display panel and fix it with glue. Place the three clamps for the contact of the ground connection tare key overlay-display panel. Check new tare key overlay. Use perenator to seal the joint around the tare key overlay and allow for several hours drying time.

4. Recommended Spare Parts for Analytic Balance Model A 200 S.

<u>Part Number</u>	<u>Description</u>	<u>Quantity</u>
69 13019	Leveling Screw	1 ea
69 A20007-4	Overlay with Switch	1 ea
69 A20020-1	Front Glass Plate	1 ea
69 A20023-6	Rear Glass Plate	1 ea
6970920	AC/DC Adapter (115V) (US)	1 ea
69709170-0	LC-Display (A 200 S)	1 ea

APPENDIX A
REFERENCES

A-1. Scope. This appendix contains all forms, pamphlets and technical manuals referenced in both the Air mobile and Semitrailer mounted Laboratories.

A-2. Forms.

Recommended Changes to Publications	DA Form 2028 DA Form 2028-2
Quality Deficiency Report	SF 368
Equipment Inspection and Maintenance Work Sheet	DA Form 2404
Hand Receipts	DA Form 2062

A-3. Field Manuals.

Petroleum Testing Facilities:	
Laboratories and Kits	FM 10-72
Inspecting and Testing Petroleum Products	FM 10-70
ASTM Test Method Supplement to	FM 10-92C1/C2

A-4. Technical Manuals.

Atlas-Copco Compressor	TM 10-4310-392-13&P
Alcor Jet Fuel Thermal Oxidation Tester Operating and Maintenance Manual	TM 10-6635-210-13&P
Bacharach Gas Alarm and Calibration Data	TM 10-6665-297-13&P
Brother Portable Typewriter	TM 10-7430-218-13&P
Chemtrix Field Ph Meter	TM 10-6630-237-13&P
Elkay Manufacturing 30 GPH Cooler	TM 10-4130-240-13&P
Emcee Micro-Separometer	TM 10-6640-222-13&P
Foxboro Pressure Recording Gauge	TM 10-6685-365-13&P
Gammon Aqua Glo Water Detector	TM 10-6640-221-13&P
Gammon Mini Monitor Fuel Sampling Kit	TM 10-6630-230-13&P
Jelrus Burn-Out Furnace	TM 10-6640-231-13&P
Koehler Cleveland Open Tester	TM 10-6630-236-13&P
Koehler Cloud and Pour Point Chamber	TM 10-6630-238-13&P
Koehler Copper Strip Corrosion Bomb Bath	TM 10-6640-220-13&P
Koehler Distillation Apparatus	TM 10-6630-233-13&P
Koehler Dropping Point Apparatus	TM 10-6635-211-13&P
Koehler Electric Pensky-Martins Tester	TM 10-6630-231-13&P
Koehler Foaming Characteristics Determination Apparatus	TM 10-6640-228-13&P
Koehler Kinematic Viscosity Bath	TM 10-6630-239-13&P
Koehler Tag Closed Cup Flash Tester	TM 10-6630-235-13&P
Lab-Line Explosion Proof Refrigerator	TM 10-6640-219-13&P
Lily Freezer	TM 10-6640-234-13&P
Millipore OM 39 Filter Holder	TM 10-6640-225-13&P
Millipore Vacuum Pump	TM 10-6640-217-13&P
Ohaus Harvard Trip Balance	TM 10-6670-278-13&P
Precision Gas-Oil Distillation Test Equipment	TM 10-6630-219-13&P
Precision General Purpose Water Bath	TM 10-6640-229-13&P

TM 10-6670-277-13&P

Precision High Temperature Bronze Block Gum Bath	TM 10-6630-234-13&P
Precision General Purpose Ovens	TM 10-6640-218-13&P
Precision Heater Instruction Manual and Parts List	TM 10--6640-223-13&P
Precision Oxidation Stability Bath	TM 10-6640-232-13&P
Precision Pensky–Martens Flash Testers	TM 10-6630-231-13&P
Precision Reid Vapor Pressure Bath	TM 10-6640-226-13&P
Precision Slo–Speed Stirrer	TM 10-6640-224-13&P
Precision Universal Centrifuge	TM 10-6640-230-13&P
Precision Universal Penetrometer	TM 10-6640–228–13&P
Sargent–Welch Vacuum Pump	TM 10-4310–391–13&P
Sartorius Analytical Balance.	TM 10-6670–277–13&P
Scotsman Cuber	TM 10-6640-227-13&P
Soltec VOM–Multimeter	TM 10–6625–3127–13&P
Teel Self–Priming Centrifugal Pump	TM 10-6640-217-13&P
Teel Submersible Pump	TM 10-4320–320–13&P
Texas instrument TI–5030II Calculator	TM 10–7420–210–13&P

A–5. Pamphlets.

The Army Maintenance Management System (TAMMS)	DA Pam 738–750
--	----------------

A–6. Miscellaneous Publications.

The Army Integrated Publishing and Printing Program	AR 25–30
Laboratory, Airmobile, Aviation Fuel	MIL–L–52733A(ME)
Apparatus, instruments, Chemicals, Furniture, and Supplies for Industrial, Clinical, College and Government Laboratories	Fisher Scientific Laboratories Catalog
Petroleum–Petrochemical Testing Equipment	Precision Scientific Catalog

APPENDIX B

MAINTENANCE ALLOCATION CHART

Section I. INTRODUCTION

B-1. General.

a. This section provides a general explanation of all maintenance and repair functions authorized at various maintenance categories.

b. The Maintenance Allocation Chart (MAC) in Section II designates overall authority and responsibility for the performance of maintenance functions on the identified end item or component. The application of the maintenance functions to the end item or component will be consistent with the capacities and capabilities of the designated maintenance categories.

c. Section III lists the tools and test equipment (both special tools and common tool sets) required for each maintenance function as referenced from Section II.

d. Section IV contains supplemental instructions and explanatory notes for a particular maintenance function.

B-2. Maintenance Functions. Maintenance functions will be limited to and defined as follows:

a. *Inspect.* To determine the serviceability of an item by comparing its physical, mechanical, and/or electrical characteristics with established standards through examination (e.g., by sight, sound, or feel).

b. *Test.* To verify serviceability by measuring the mechanical, pneumatic, hydraulic, or electrical characteristics of an item and comparing those characteristics with prescribed standards.

c. *Service.* Operations required periodically to keep an item in proper operating Condition i.e., to clean (includes decontaminate, when required), to preserve, to drain, to paint, or to replenish fuel, lubricants, chemical fluids, or gases.

d. *Adjust.* To maintain or regulate, within prescribed limits, by bringing into proper or exact position, or by setting the operating characteristics to specified parameters.

e. *Align.* To adjust specified variable elements of an item to bring about optimum or desired performance.

f. *Galibrate.* To determine and cause corrections to be made or to be adjusted on instruments Or test, measuring, and diagnostic equipments used in precision measurement. Consists of comparisons of two instruments, one of which is a certified standard of knob accuracy, to detect and adjust any discrepancy in the accuracy of the instrument being compared.

g. *Remove/Install* To remove and install the same item when required to perform service or other maintenance functions. Install maybe the act of emplacing, seating, or fixing into position a spare, repair part, or module (component or assembly) in a manner to allow the proper functioning of an equipment or system.

h. *Replace.* To remove an unserviceable item and install a serviceable counterpart in its place. "Replace" is authorized by the MAC and is shown as the third position code of the SMR code.

i. Repair. The application of maintenance services, ¹including fault location/troubleshooting,² removal/installation, and disassembly/assembly procedures³ and maintenance actions⁴ to identify troubles and restore serviceability to an item by correcting specific damage, fault, malfunction, or failure in a part, subassembly, module (component or assembly), end item, or system.

j. Overhaul. That maintenance effort (service/action) prescribed to restore an item to a completely serviceable/operational condition as required by maintenance standards in appropriate technical publications (i.e, DMWR). Overhaul is normally the highest degree of maintenance performed by the Army. Overhaul does not normally return an item to like–new condition.

k. Rebuild. Consists of those services/actions necessary for the restoration of unserviceable equipment to a like–new condition in accordance with original manufacturing standards. Rebuild is the highest degree of materiel maintenance applied to Army equipment. The rebuild operation includes the act of returning to zero those age measurements (hours/miles, etc.) considered in classifying Army equipment/components.

B–3. Explanation Of Columns In The MAC, Section II.

a. Column 1. Group Number. Column 1 lists functional group code numbers, the purpose of which is to identify maintenance significant components, assemblies, subassemblies, and modules with the next higher assembly. End item group number shall be “00.”

b. Column 2. Component/Assembly. Column 2 contains the names of components, assemblies, subassemblies, and modules for which maintenance is authorized.

c. Column 3. Maintenance Function. Column 3 lists the functions to be performed on the item listed in column 2. (For a detailed explanation of these functions, see paragraph B–2.)

d. Column 4. Maintenance Category. Column 4 specifies, by the listing of a work time figure in the appropriate subcolumn(s), the category of maintenance authorized to perform the function listed in column 3. This figure represents the active time required to perform that maintenance function at the indicated category of maintenance. If the number or complexity of the tasks within the listed maintenance function vary at different maintenance categories, appropriate work time figures will be shown for each category. The work time figure represents the average time required to restore an item (assembly, subassembly, component, module, end item, or system) to a serviceable condition under typical field operating conditions. This time includes preparation time (including any necessary disassembly/assembly time), troubleshooting/fault location time, and quality assurance/quality control time in addition to the time required to perform the specific tasks identified for the maintenance functions authorized in the maintenance allocation chart. The symbol designations for the various maintenance categories are as follows:

¹ Services – inspect, test, service, adjust, align, calibrate, and/or replace.

² Fault locate/troubleshoot – the process of investigating and detecting the cause of equipment malfunctioning; the act of isolating a fault within a system or unit under test (UUT).

³ Disassemble/assemble – encompasses the step-by-step taking apart (or breakdown) of a spare/functional group coded item to the/eve/of its/east componency identified as maintenance significant (i. e., assigned an SMR code) for the category of maintenance under consideration.

⁴ Actions – welding, grinding, riveting, straightening, facing, remachining, and/or resurfacing.

- C Operator/Crew
- O Unit Maintenance
- F Direct Support Maintenance
- H General Support Maintenance
- D Depot Maintenance

e. Column 5. Tools and Equipment. Column 5 specifies, by code, those common tool sets (not individual tools) and special tools, TMDE, and support equipment required to perform the designated function.

f. Column 6. Remark. This column shall, when applicable, contain a letter code, in alphabetic order, which shall be keyed to the remarks contained in section IV.

B-4. Explanation Of Columns In Tool And Test Equipment Requirements, Section III.

a. Column 1. Reference Code. The tool and test equipment reference code correlates with a code used in the MAC, section II, column 5.

b. Column 2. Maintenance Category. The lowest category of maintenance authorized to use the tool or test equipment.

c. Column 3. Nomenclature. Name or identification of the tool or test equipment.

d. Column 4. National Stock Number. The National stock number of the tool or test equipment.

e. Column 5. Too/ Number. The manufacturer's part number.

B-5. Explanation Of Columns In Remarks, Section IV.

a. Column 1. Reference Code. The code recorded in column 6, Section II.

b. Column 2. Remarks. This column lists information pertinent to the maintenance function being performed as indicated in the MAC, section II.

Section II. MAINTENANCE ALLOCATION CHART

(1) GROUP NUMBER	(2) COMPONENT/ ASSEMBLY	(3) MAINTENANCE FUNCTION	(4) MAINTENANCE LEVEL					(5) TOOLS AND EQUIPMENT	(6) REMARKS
			UNIT		DS	GS	DEPOT		
			C	O	F	H	D		
01	ANALYTIC BALANCE	INSPECT REPLACE REPAIR	0.2	0.5	1.0			1,2	

SECTION III. TOOL AND TEST EQUIPMENT REQUIREMENTS

MAINTENANCE ALLOCATION CHART

(1) TOOL/TEST EQUIP. REF CODE	(2) MAINTENANCE CATEGORY	(3) NOMENCLATURE	(4) NSN	(5) TOOL NUMBER
1	F	TOOL KIT, GENERAL AUTOMOTIVE	5180-00-177-7033	(50980) SC5180-90- CL-N26
2	F	MULTIMETER, 0-500V	6625-00-691-2453	

SECTION IV. REMARKS

NOT APPLICABLE

APPENDIX C

COMPONENTS OF END ITEM AND BASIC ISSUE ITEMS LISTS

Section I. INTRODUCTION

C-1. Scope.

This appendix lists components of end item and basic issue items for the Analytic Balance to help you inventory items required for safe and efficient operation.

C-2. General.

The Components of End Item and Basic Issue Items Lists are divided into the following sections:

a. Section II. Components of End Item. This listing is for informational purposes only, and is not authority to requisition replacements. These items are part of the end item, but are removed and separately packaged for transportation or shipment. As part of the end item, these items must be with the end item whenever it is issued or transferred between property accounts. Illustrations are furnished to assist you in identifying the items.

b. Section III. Basic Issue Items. These are the minimum essential items required to place the Analytic Balance in operation, to operate it, and to perform emergency repairs. Although shipped separately packaged, BII must be with the shelter during operation and whenever it is transferred between property accounts. The illustrations will assist you with hard-to-identify items. This manual is your authority to request/requisition replacement BII, based on TOE/MTOE authorization of the end item.

C-3. Explanation of Columns.

The following provides an explanation of columns found in the tabular listings:

a. Column (1) – Illustration Number (Illus Number). This column indicates the number of the illustration in which the item is shown.

b. Column (2) – National Stock Number. Indicates the National stock number assigned to the item and will be used for requisitioning purposes.

c. Column (3) – Description. Indicates the Federal item name and, if required, a minimum description to identify and locate the item. The last line for each item indicates the CAGEC (in parentheses) followed by the part number.

d. Column (4) – Unit of Measure (U/M). Indicates the measure used in performing the actual operational/maintenance function. This measure is expressed by a two-character alphabetical abbreviation (e.g., ea, in, pr).

e. Column (5) – Quantity required (QTY RQR). Indicates the quantity of the item authorized to be used with/on the equipment.

SECTION II. COMPONENTS OF END ITEM

(1)	(2)	(3)	(4)	(5)
ILLUS	NATIONAL STOCK NUMBER	DESCRIPTION CAGEC AND PART NUMBER	USABLE ON CODE	QTY
	7920-00-205-0565	BRUSH, DUSTING, LENS AND PHOTOGRAPHIC NEGATIVE; CAMEL HAIR, METAL FERRULE, 1 IN. WIDE, 6 IN. LONG; BRISTLE, 1 IN. LONG WITH WOOD HANDLE; H-B-1654	EA	1
	6670-00-803-9680	WEIGHT SET, BALANCE, 1 TO 1000GM; CLASS C; BRASS; AAA-W-200	SE	1

SECTION III. BASIC ISSUE ITEMS

NOT APPLICABLE

APPENDIX D
ADDITIONAL AUTHORIZATION LIST
NOT APPLICABLE

APPENDIX E

EXPENDABLE/DURABLE SUPPLIES AND MATERIALS LIST

Section I. INTRODUCTION

E-1. Scope. This listing is for informational purposes only and is not authority to requisition the listed items. These items are authorized to you by CTA 50-970, Expendable/Durable Items (except medical, class V, repair parts, and heraldic items).

E-2. Explanation of Columns.

a. Column (1) - Item Number. This number is assigned to the entry in the listing and is referenced in the narrative instructions to identify the material (e.g., Use cleaning compound, item 5, appendix C).

b. Column (2) - Level. This column identifies the lowest level of maintenance that requires the listed item.

- C - Operator/Crew
- O - Unit Maintenance
- F - Direct Support Maintenance
- H - General Support Maintenance

c. Column (3) - National Stock Number. This is the National stock number assigned to the item; use it to request or requisition the item.

d. Column (4) - Description. Indicates the Federal item name, and, if required, a description to identify the item. The last line for each item indicates the Commercial and Government Entity Code (CAGEC) in parentheses followed by the part number.

e. Column (5) - Unit of Measure (W/M). Indicates the measure used in performing the actual maintenance function. This measure is expressed by a two-character alphabetical abbreviation (e.g., EA, IN, PR). If the unit of measure differs from the unit of issue, requisition the lowest unit of issue that will satisfy your requirements.

Section II. EXPENDABLE/DURABLE SUPPLIES AND MATERIALS LIST

(1) Item Number	(2) Level	(3) National Stock Number	(4) Description	(5) U/M
	C	6145-00-299-5186	WIRE, ELECTRICAL: COPPER ; SOFT MATERIAL; SOLID CONDUCTOR; RED; No. 16 AWG; UNCOATED; 875.20 OHMS PER MILE - 1 LB.; 20°C; QQ-W-343, TYPES	LB

By Order of the Secretary of the Army:

CARL E. VUONO
General, United States Army
Chief of Staff

Official:

THOMAS F. SIKORA
Brigadier General, United States Army
The Adjutant General

DISTRIBUTION:

To be distributed in accordance with DA Form 12-21A, Operator, Unit and Direct Support Maintenance requirements for Laboratory, Air Mobile, Aviation Fuel and Laboratory, Petroleum, MTD



THEN... JOT DOWN THE DOPE ABOUT IT ON THIS FORM. CAREFULLY TEAR IT OUT, FOLD IT AND DROP IT IN THE MAIL!

SOMETHING WRONG WITH THIS PUBLICATION?

FROM: (PRINT YOUR UNIT'S COMPLETE ADDRESS)

PFC JOHN DOE
COA, 3d ENGINEER BN
FT. LEONARD WOOD, MO 63108

DATE SENT

PUBLICATION NUMBER

TM 10-6670-277-13&P

PUBLICATION DATE

10 Oct 1990

PUBLICATION TITLE

Analytic Balance

BE EXACT PIN-POINT WHERE IT IS

PAGE NO	PARA-GRAPH	FIGURE NO	TABLE NO
6	2-1 a		
B1		4-3	
125	line 20		

IN THIS SPACE TELL WHAT IS WRONG AND WHAT SHOULD BE DONE ABOUT IT:

In line 6 of paragraph 2-1a the manual states the engine has 6 cylinders. The engine on my set only has 4 cylinders. Change the manual to show 4 cylinders.

Callout 16 on figure 4-3 is pointing at a bolt. In key to figure 4-3, item 16 is called a shim - Please correct one or the other.

I ordered a gasket, item 19 on figure B-16 by NSN 2 910-00-762-3001. I got a gasket but it doesn't fit. Supply says I got what I ordered, so the NSN is wrong. Please give me a good NSN

PRINTED NAME, GRADE OR TITLE AND TELEPHONE NUMBER

JOHN DOE, PFC (268) 317-7111

SIGN HERE

JOHN DOE

DA FORM 1 JUL 79 2028-2

PREVIOUS EDITIONS ARE OBSOLETE.

DRSTS-M Overprint 1, 1 Nov 80

PS --IF YOUR OUTFIT WANTS TO KNOW ABOUT YOUR RECOMMENDATION MAKE A CARBON COPY OF THIS AND GIVE IT TO YOUR HEADQUARTERS

TEAR ALONG PERFORATED LINE

FILL IN YOUR
UNIT'S ADDRESS



FOLD BACK

DEPARTMENT OF THE ARMY

OFFICIAL BUSINESS

COMMANDER
U.S. ARMY TROOP SUPPORT COMMAND
ATTN: AMSTR-MCTS
4300 GOODFELLOW BOULEVARD
ST. LOUIS, MO 63120-1798

TEAR ALONG PERFORATED LINE

RECOMMENDED CHANGES TO EQUIPMENT TECHNICAL PUBLICATIONS

SOMETHING WRONG WITH THIS PUBLICATION?



THEN... JOT DOWN THE DOPE ABOUT IT ON THIS FORM. CAREFULLY TEAR IT OUT. FOLD IT AND DROP IT IN THE MAIL!

FROM: (PRINT YOUR UNIT'S COMPLETE ADDRESS)

DATE SENT

PUBLICATION NUMBER

TM 10-6670-277-13&P

PUBLICATION DATE

10 Oct 1990

PUBLICATION TITLE

Analytic Balance

BE EXACT PIN-POINT WHERE IT IS

PAGE NO

PARA-GRAPH

FIGURE NO

TABLE NO

IN THIS SPACE TELL WHAT IS WRONG AND WHAT SHOULD BE DONE ABOUT IT:

TEAR ALONG PERFORATED LINE

PRINTED NAME, GRADE OR TITLE, AND TELEPHONE NUMBER

SIGN HERE

DA FORM 2028-2
1 JUL 79

PREVIOUS EDITIONS ARE OBSOLETE.
DRSTS-M Overprint 2, 1 Nov 80.

P.S.--IF YOUR OUTFIT WANTS TO KNOW ABOUT YOUR RECOMMENDATION MAKE A CARBON COPY OF THIS AND GIVE IT TO YOUR HEADQUARTERS.

FILL IN YOUR
UNIT'S ADDRESS

FOLD BACK

DEPARTMENT OF THE ARMY

OFFICIAL BUSINESS

COMMANDER
U.S. ARMY TROOP SUPPORT COMMAND
ATTN: AMSTR-MCTS
4300 GOODFELLOW BOULEVARD
ST. LOUIS, MO 63120-1798

TEAR ALONG PERFORATED LINE

RECOMMENDED CHANGES TO EQUIPMENT TECHNICAL PUBLICATIONS

SOMETHING WRONG WITH THIS PUBLICATION?



THEN... JOT DOWN THE DOPE ABOUT IT ON THIS FORM. CAREFULLY TEAR IT OUT, FOLD IT AND DROP IT IN THE MAIL!

FROM: (PRINT YOUR UNIT'S COMPLETE ADDRESS)

DATE SENT

PUBLICATION NUMBER

TM 10-6670-277-13&P

PUBLICATION DATE

10 Oct 1990

PUBLICATION TITLE

Analytic Balance

BE EXACT PIN-POINT WHERE IT IS

PAGE NO

PARA-GRAPH

FIGURE NO

TABLE NO

IN THIS SPACE TELL WHAT IS WRONG AND WHAT SHOULD BE DONE ABOUT IT:

TEAR ALONG PERFORATED LINE

PRINTED NAME, GRADE OR TITLE, AND TELEPHONE NUMBER

SIGN HERE

DA FORM 2028-2
1 JUL 79

PREVIOUS EDITIONS ARE OBSOLETE.
DRSTS-M Overprint 2, 1 Nov 80.

P.S.--IF YOUR OUTFIT WANTS TO KNOW ABOUT YOUR RECOMMENDATION MAKE A CARBON COPY OF THIS AND GIVE IT TO YOUR HEADQUARTERS

FILL IN YOUR
UNIT'S ADDRESS



FOLD BACK

DEPARTMENT OF THE ARMY

OFFICIAL BUSINESS

COMMANDER
U.S. ARMY TROOP SUPPORT COMMAND
ATTN: AMSTR-MCTS
4300 GOODFELLOW BOULEVARD
ST. LOUIS, MO 63120-1798

TEAR ALONG PERFORATED LINE

RECOMMENDED CHANGES TO EQUIPMENT TECHNICAL PUBLICATIONS



THEN... JOT DOWN THE DOPE ABOUT IT ON THIS FORM. CAREFULLY TEAR IT OUT, FOLD IT AND DROP IT IN THE MAIL!

SOMETHING WRONG WITH THIS PUBLICATION?

FROM: (PRINT YOUR UNIT'S COMPLETE ADDRESS)

DATE SENT

PUBLICATION NUMBER
TM 10-6670-277-13&P

PUBLICATION DATE
10 Oct 1990

PUBLICATION TITLE
Analytic Balance

BE EXACT PIN-POINT WHERE IT IS

PAGE NO	PARA- GRAPH	FIGURE NO	TABLE NO

IN THIS SPACE TELL WHAT IS WRONG AND WHAT SHOULD BE DONE ABOUT IT:

TEAR ALONG PERFORATED LINE

PRINTED NAME, GRADE OR TITLE, AND TELEPHONE NUMBER

SIGN HERE

FILL IN YOUR
UNIT'S ADDRESS



FOLD BACK

DEPARTMENT OF THE ARMY

OFFICIAL BUSINESS

COMMANDER
U.S. ARMY TROOP SUPPORT COMMAND
ATTN: AMSTR-MCTS
4300 GOODFELLOW BOULEVARD
ST. LOUIS, MO 63120-1798

TEAR ALONG PERFORATED LINE

The Metric System and Equivalents

Linear Measure

1 centimeter = 10 millimeters = .39 inch
 1 decimeter = 10 centimeters = 3.94 inches
 1 meter = 10 decimeters = 39.37 inches
 1 dekameter = 10 meters = 32.8 feet
 1 hectometer = 10 dekameters = 328.08 feet
 1 kilometer = 10 hectometers = 3,280.8 feet

Weights

1 centigram = 10 milligrams = .15 grain
 1 decigram = 10 centigrams = 1.54 grains
 1 gram = 10 decigrams = .035 ounce
 1 dekagram = 10 grams = .35 ounce
 1 hectogram = 10 dekagrams = 3.52 ounces
 1 kilogram = 10 hectograms = 2.2 pounds
 1 quintal = 100 kilograms = 220.46 pounds
 1 metric ton = 10 quintals = 1.1 short tons

Liquid Measure

1 centiliter = 10 milliliters = .34 fl. ounce
 1 deciliter = 10 centiliters = 3.38 fl. ounces
 1 liter = 10 deciliters = 33.81 fl. ounces
 1 dekaliter = 10 liters = 2.64 gallons
 1 hectoliter = 10 dekaliters = 26.42 gallons
 1 kiloliter = 10 hectoliters = 264.18 gallons

Square Measure

1 sq. centimeter = 100 sq. millimeters = .155 sq. inch
 1 sq. decimeter = 100 sq. centimeters = 15.5 sq. inches
 1 sq. meter (centare) = 100 sq. decimeters = 10.76 sq. feet
 1 sq. dekameter (are) = 100 sq. meters = 1,076.4 sq. feet
 1 sq. hectometer (hectare) = 100 sq. dekameters = 2.47 acres
 1 sq. kilometer = 100 sq. hectometers = .386 sq. mile

Cubic Measure

1 cu. centimeter = 1000 cu. millimeters = .06 cu. inch
 1 cu. decimeter = 1000 cu. centimeters = 61.02 cu. inches
 1 cu. meter = 1000 cu. decimeters = 35.31 cu. feet

Approximate Conversion Factors

To change	To	Multiply by	To change	To	Multiply by
inches	centimeters	2.540	ounce-inches	newton-meters	.007062
feet	meters	.305	centimeters	inches	.394
yards	meters	.914	meters	feet	3.280
miles	kilometers	1.609	meters	yards	1.094
square inches	square centimeters	6.451	kilometers	miles	.621
square feet	square meters	.093	square centimeters	square inches	.155
square yards	square meters	.836	square meters	square feet	10.764
square miles	square kilometers	2.590	square meters	square yards	1.196
acres	square hectometers	.405	square kilometers	square miles	.386
cubic feet	cubic meters	.028	square hectometers	acres	2.471
cubic yards	cubic meters	.765	cubic meters	cubic feet	35.315
fluid ounces	milliliters	29.573	cubic meters	cubic yards	1.308
pints	liters	.473	milliliters	fluid ounces	.034
quarts	liters	.946	liters	pints	2.113
gallons	liters	3.785	liters	quarts	1.057
ounces	grams	28.349	liters	gallons	.264
pounds	kilograms	.454	grams	ounces	.035
short tons	metric tons	.907	kilograms	pounds	2.205
pound-feet	newton-meters	1.356	metric tons	short tons	1.102
pound-inches	newton-meters	.11296			

Temperature (Exact)

°F	Fahrenheit temperature	5/9 (after subtracting 32)	Celsius temperature	°C
----	------------------------	----------------------------	---------------------	----

